

# EE66 Series

## Air Velocity Transmitter for measurement down to "0" m/s

EE66 air velocity transmitter series are designed for high accuracy measurement of lowest air velocities. It is the ideal solution for laminar flow control and special ventilation applications. The E+E thin film sensor is operating on an innovative hot film anemometer principle. This guarantees excellent accuracy for air velocity down to almost 0 m/s, which is not possible for conventional anemometers with commercial temperature sensors or NTC bead thermistors. The E+E sensor is much more insensitive to pollution than all other anemometer principles. This increases reliability and reduces maintenance costs.

EE66 series are available with current or voltage output, the measuring range and the response time can be selected with jumpers by the user.

Low angular dependence enables easy, cost-effective installation.

An integrated LCD display and a version with remote sensing probe are also available.



EE66 - A / B

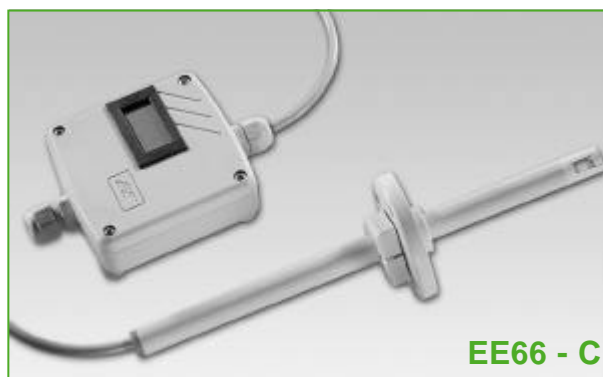

EE66 - C

### Typical Applications

clean room control  
laminar flow control

### Features

measurement down to 0 m/s  
low angular dependence  
easy installation

### Technical Data

#### Measuring values

Working range <sup>1)</sup>	0 ... 1 m/s	
	0 ... 1.5 m/s	
	0 ... 2 m/s	
Output <sup>1)</sup>	0 - 10 V	-1mA < I <sub>L</sub> < 1 mA
	4 - 20 mA	R <sub>L</sub> < 450 Ω (linear, 3 wires)
Accuracy at 20 degC, 45% RH and 1013 hPa	0 ... 1 m/s	± (0.04 m/s + 2 % of measuring value)
	0 ... 1.5 m/s	± (0.05 m/s + 2 % of measuring value)
	0 ... 2 m/s	± (0.06 m/s + 2 % of measuring value)
Response time τ <sub>90</sub> <sup>1) 2)</sup>	typ. 2 sec. or typ. 0.2 sec.	(at constant temperature)

#### General

Power supply	SELV 24VAC/DC ± 10 %
Current consumption for AC supply for DC supply	max. 150 mA
	max. 90 mA
Angular dependence	< 3 % of measurement at   Δα   < 10°
Cable gland	M16x1.5
Electrical connection	screw terminals max. 1.5 mm <sup>2</sup>
Electromagnetic compatibility	EN 50081-1
	EN 50082-1      EN 50082-2
Housing / protecting class	Polycarbonat / IP65, with LC-display: IP40

1) Selectable by jumper

2) Response time τ<sub>90</sub> is measured from the beginning of a step change of air velocity to the moment of reaching 90% of the step.



Temperature range	working temperature probe	-25 ... +50 degC
	working temperature electronic	-10 ... +50 degC
	storage temperature	-30 ... +60 degC

## Dimensions (mm)

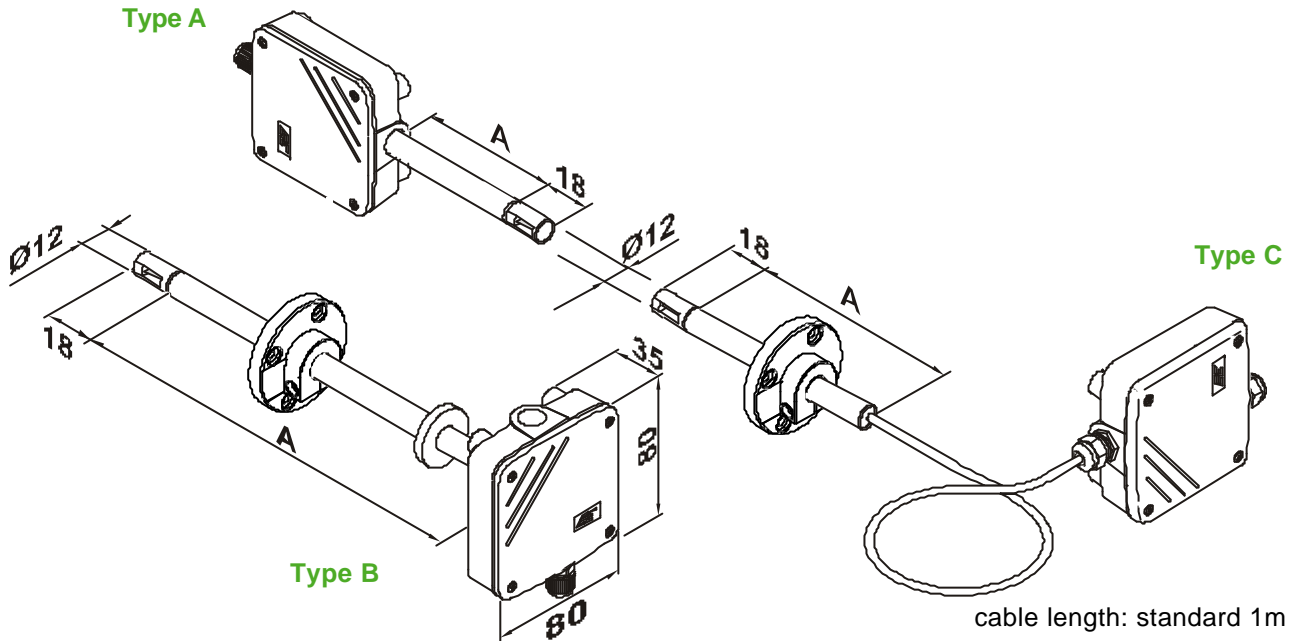

## Connection Diagram

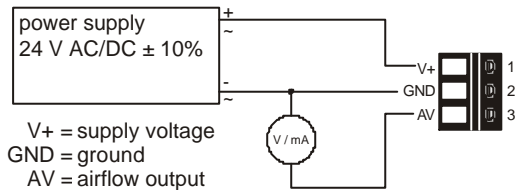

## Ordering Guide

MODEL	HOUSING	PROBE LENGTH (according to "A")	CABLE LENGTH (only Typ C)	DISPLAY
velocity (V)	wall mounting (A)	100 mm (3)	1 m (no code)	without display (no code)
	duct mounting (B)	200 mm (5)	2 m (K200)	with display (D02)
	seperated sensor probe (C)	others (x)	5 m (K500) 10 m (K1000)	
EE66-				

## Order Example

### EE66-VB5-D02

model: velocity  
housing: duct mounting  
probe length: 200 mm  
display: with LC-display